

INSTRUCTIONS IMPORTANT SAFEGUARDS

When using electrical equipment, basic safety precautions should always be followed including the following:

1. **READ AND FOLLOW ALL SAFETY INSTRUCTIONS**
2. Risk of fire or electric shock. Luminaire wiring and electrical parts may be damaged when drilling for installation of LED Emergency Backup. Check for enclosed wiring and components.
3. Risk of fire or electric shock. This LED Emergency Backup installation requires knowledge of luminaires electrical systems. If not qualified, do not attempt installation. Contact a qualified electrician.
4. Before installing, make certain the AC power to the fixture is off.
5. The electrical rating of this product is 100-277Vac. Installer must confirm that there is 100-277Vac in the fixture before installation.
6. To prevent electrical shock, only mate unit connector after installation is complete and before the AC power to the fixture is back on.
7. Do not use outdoors.
8. This LED Emergency Backup unit requires an un-switched AC power source of 100-277Vac, 50/60Hz. The AC driver must be on the same branch circuit as the LED Emergency Backup unit.
9. Do not let power supply cords touch hot surfaces.
10. Do not mount near gas or electric heaters.
11. Do not join battery pack connector until all other wiring is complete and AC power is on.
12. Equipment should be mounted in locations and at heights where it will not be subjected to tampering by unauthorized personnel.
13. The use of accessory equipment not recommended by the manufacturer may cause an unsafe condition.
14. Do not use this equipment for other than its intended use.
15. Use with grounded, UL Listed, dry or damp location rated fixtures.

WIRING DIAGRAM

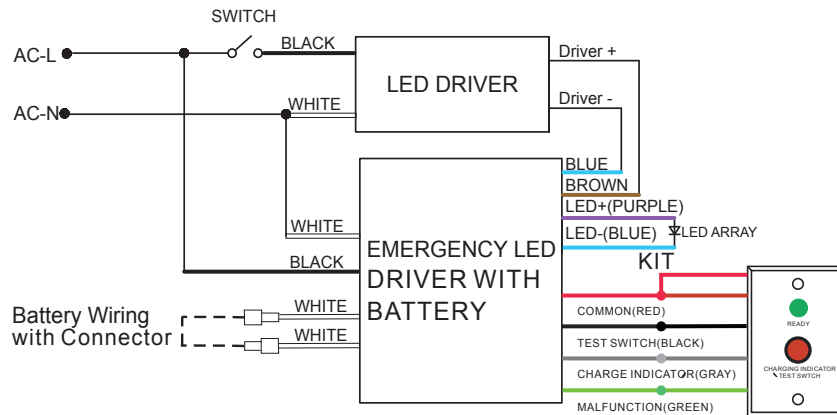

1. DO NOT MATE CONNECTOR UNTIL INSTALLATION IS COMPLETE AND AC POWER IS SUPPLIED.
2. TEST ACCESSORY LEADS-OBSERVE PROPER POLARITY WIRING.

DIMENSIONS

Case - 15" X 2.24" X 1.3" (mounting center - 14.4")

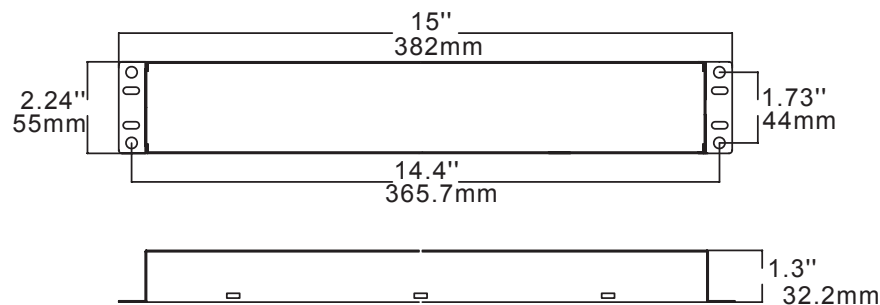

INSTALLATION

APPLICATION

The emergency driver can be used with most LED loads that have a rated voltage of 25-48Vdc. These emergency driver have been evaluated to and found compliant to UL 924. The emergency pack assembly is accepted as a component of a luminaire where the suitability of the combination shall be determined by UL or Authorities Having Jurisdiction. The as-installed performance of the system must meet or exceed all Federal, State, and Local code requirements.

OPERATION

AC Operation: AC power is present. The AC driver operates the LED load as designed. AC LED driver that has an output current not to exceed 4.0 A. The emergency pack is charging in a standby mode. The charging indicator will be lit, showing that the battery is charging.

Emergency Operation: When the AC power goes out, the emergency pack detects the power outage and automatically switches to the emergency mode. The charging indicator will be off. The LED load is illuminated for a minimum of 90 minutes. When AC power is restored, the emergency pack switches back to Normal Mode and starts re-charging.

Malfunction Mode: When the emergency driver internal circuit is without fault and battery is normal, the green LED will be lit. When battery is disconnected and the emergency driver circuit faults, the green LED is off.

DIAL SWITCH CODE SELECTION

LL48

Emergency Power			
Power	Voltage	1	2
8W	25-48Vdc	—	—
6W		—	0N
4W		0N	—

NOTE: When the dial switch code 1 and 2 turn off, the emergency power is 8W, 1 turn off and 2 turn on, the emergency power is 6W, 1 turn on and 2 turn off, the emergency power is 4W.

LL815

Emergency Power			
Power	Voltage	1	2
15W	25-48Vdc	—	—
12W		—	0N
8W		0N	—

NOTE: When the dial switch code 1 and 2 turn off, the emergency power is 15W, 1 turn off and 2 turn on, the emergency power is 12W, 1 turn on and 2 turn off, the emergency power is 8W.

LL1020

Emergency Power			
Power	Voltage	1	2
20W	25-48Vdc	—	—
15W		—	0N
10W		0N	—

NOTE: When the dial switch code 1 and 2 turn off, the emergency power is 20W, 1 turn off and 2 turn on, the emergency power is 15W, 1 turn on and 2 turn off, the emergency power is 10W.